



OTC08 19498

A NOVEL METHOD FOR COILED TUBING INSTALLATION

Peter James Simpson, 2H Offshore and David Tibbetts, Aquatic Engineering and Construction Ltd

Copyright 2008, Offshore Technology Conference

This paper was prepared for presentation at the 2008 Offshore Technology Conference held in Houston, Texas, U.S.A., 5–8 May 2008.

This paper was selected for presentation by an OTC program committee following review of information contained in an abstract submitted by the author(s). Contents of the paper have not been reviewed by the Offshore Technology Conference and are subject to correction by the author(s). The material does not necessarily reflect any position of the Offshore Technology Conference, its officers, or members. Electronic reproduction, distribution, or storage of any part of this paper without the written consent of the Offshore Technology Conference is prohibited. Permission to reproduce in print is restricted to an abstract of not more than 300 words; illustrations may not be copied. The abstract must contain conspicuous acknowledgment of OTC copyright.

Abstract

Installation of flexible pipe for offshore developments is costly due to the physical cost of the flexible pipe, expensive day rates and the availability of suitable installation vessels. Considering the scarcity of flexible pipe in today's increasingly demanding and busy market, operators are seeking a cost effective solution for installing piping in a range of water depths using vessels which are readily on hand.

This paper describes a novel approach to installing reeled coiled tubing, from 1inch to 5inch diameter, from the back of a small vessel in water depths from 40m up to around 1000m. The uniqueness of the system is the fact that the equipment design is modular and compact. This means that when disassembled, it fits into standard 40 ft shipping containers, and the size allows it to be installed on even relatively small vessels of opportunity, such as anchor handling or installation vessels, from smaller, and cheaper quayside locations. Such an approach is the ideal solution to the problem faced by operators, in that it allows the installation of cheaper, readily available coiled tubing, from cost-effective vessels, which do not need to transit to a pick up the system.

Introduction

Flexible pipe technology has developed rapidly in order to meet the increasingly demanding requirements of the offshore industry. As offshore developments have progressed into deeper and more challenging environments, flexible pipe manufacturers have been pressing to provide new flexible pipe technologies suitable to the task.

The natural advantages of flexible pipe over rigid pipelines make it the preferred solution for many shallow water developments, however, its convenience means that there is enormous demand for the product. Such is the need for flexible pipe that factories are working at maximum production and long lead times and high prices are commonplace. Once produced, the pipe still needs to be installed and the available installation vessels are not only expensive, but are usually operating on long term contracts, needing to be booked many months or years in advance.

However, there is an alternative to using flexible pipe for some offshore situations.

Coiled tubing is a proven technology which has largely been forgotten. The use of coiled tubing has occurred to a number of people, but until now the advantages of availability and low cost were offset by requiring the same assets as flexible pipe to install it. Aberdeen based Aquatic Engineering and Construction Ltd, (Aquatic) has long been involved in laying Coiled tubing and had identified the need for a less devoted spread, one which could compliment the traditional systems in the small to medium market. It would, by necessity, be a system designed to use a wide range of available vessels and be mobilised in a cost effective and efficient manner. In order to realise this modular, compact solution for the Lay Ramp, Aquatic have commissioned 2H Offshore, a sister Acteon company, for the design. 2H has a broad-based design capability consistent with the magnitude of the task to accomplish this complex piece of machinery.

This paper considers coiled tubing as an attractive alternative to flexible pipe, which can now be installed cheaply and easily from smaller vessels of opportunity.

Introduction to Coiled Tubing

As long ago as 1944, engineers were faced with installing subsea pipelines using a reliable and easily deployable design. The project in question was to supply the allied army with fuel oil after the D-day invasion; the pipes needed to be installed quickly and efficiently using whatever vessels and crew were available. The solution devised by British engineers was to lay twentythree 3" pipelines across the English channel, varying from 30 to 70miles long (48km to 113km). The pipe was made in 4000ft (1219m) sections, butt welded together, stored in reels and deployed across the English channel.

Sixty four years later, coiled tubing is still widely produced and used in offshore developments around the world. Coiled tubing is typically between 1" to 5" OD and produced in yield strengths of 70, 80, 90 and 100 ksi material with a relatively thin wall section. For projects in water depths up to 1000m water depth, the significant benefits of coiled tubing are:

- It is readily available and easily produced
- It is significantly cheaper than the equivalent length of flexible pipe
- It can be deployed cheaply and easily from the back of small vessels of opportunity, such as anchor handling vessels from cheaper quay-side locations.

Such are coiled tubing's benefits for less demanding applications that it is becoming increasingly seen as a viable alternative to flexible pipe for certain applications. Aberdeen based Aquatic has long been involved in laying Coiled tubing and had identified the need for a less dedicated spread. In order to realise the design of a modular, compact solution for a Lay Ramp for small vessels, Aquatic have commissioned 2H Offshore for the design.

Coiled Deployment from Vessels of Opportunity

Coiled tubing can be wound onto reels in lengths of 2000ft to 15,000ft depending on the diameter of the pipe. These reels can be easily loaded onto a small vessel, such as an anchor handling vessel, Figure 1, from relatively basic dockside facilities. If mounted on powered reels, and when combined with a suitable tensioning and straightening, the pipe is ready to be installed offshore. An illustration of such an arrangement is shown in Figure 2. Considerable effort has gone into the design of a compact Lay Ramp, including a tensioner and straightener device which can be mobilized onto relatively small vessels of opportunity.



Figure 1 – Typical installation vessel

allow the assembled system to be lifted onto the back of the boat using more economical resources.

To make the unit as versatile and efficient as possible, it must also be equally able to handle all diameters of coiled tubing from 1inch to 5inch.

A unique feature of the system is its ability to fleet from side to side across the deck. This capability is required so that side loadings on the assembly can be optimised and the unit can be located within close proximity of the reel. As the coiled tubing is unwound from the reel its point of departure from the reel moves across the reel. The Lay ramp's ability to link with this motion allows it to be placed closer to the reel without additional components between the reel and Lay ramp.

The coiled tubing rig must comply with a number of key requirements for the successful deployment of coiled tubing offshore. It must allow for all necessary operational requirements from initial deployment of coiled pipe, cutting, make up of field joints, lay down of the pipe, recovery and abandonment.

As the nature of the equipment is to allow it to be moved from vessel to vessel, or from port to port, depending on the availability of vessels and the market's demands for coiled tubing, the unit must be modular and designed to allow rapid assembly and dismantling. The system must be designed to allow it to be broken down into components of suitable size to be transported in standard 40ft shipping containers, and also be suitably light weight to

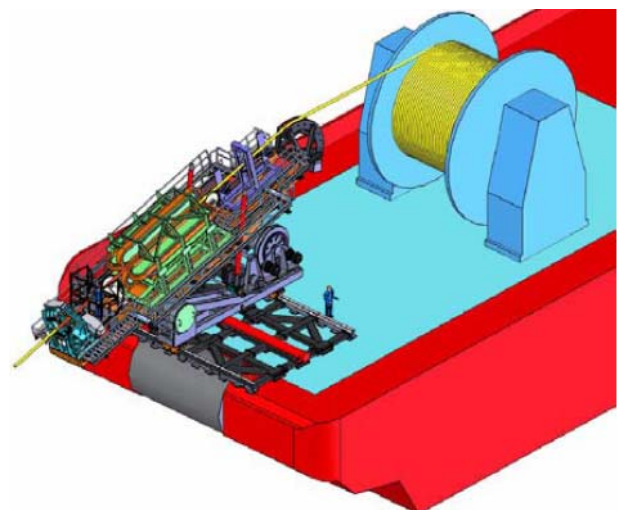

Figure 2 – Back-of-the-boat Deployment Unit

A key design principle was to use standard structural sections and readily available components. This, along with the elimination of specialist forgings allows the rig to be fabricated within a short schedule.

Another key benefit of the system is that it can also be used to deploy “flexible”; pipes, umbilicals, etc within the maximum loading of the system. This is a key feature of the unit, and offers a significantly cheaper solution than using a standard size installation vessel where project size permits. It also means that the vessel equipped with the Lay Ramp has a highly versatile range of capabilities, and can be used to install coiled tubing and/or flexible pipe, depending on the requirements of each specific project.

Key Components of the Rig

The lay ramp is composed of a number of key components which can be stored and transported in standard 40ft containers, and assembled and disassembled at a vessel berth close to the area of operations. Details of each of the components are given in the following paragraphs and shown in Figure 3:

Straightener

The straightener is the standard Aquatic system, which has a long and successful history. It is fixed to the rig by a support frame assembly and the frame provides interface connections to the straightener and roller arch. Access platforms mount onto the side of the frame via the extended shafts on each side. The frame is a modular assembly and can be exchanged depending on the requirements for the straightener and roller arch. The assembly weighs approximately 1.4Tonnes with an overall footprint of 1.2 x 3.8m.

Tensioning Device

The tensioning device shown is also a standard system produced by Aquatic. The component consists of 4 parallel track-ways, with a total tension capacity of 50Tonnes. The unit weighs approximately 40Tonnes and is mounted directly on top of the main support frame. A smaller unit can be substituted if low laying tensions are experienced.

Hang off Clamp and Roller box

The hang-off clamp assembly is a fabricated structure situated below the tensioner and is mounted directly to the main frame. The hang off clamp has a maximum hang-off capacity of 50Tonnes and a hydraulically driven trapezoidal screw provides the clamping force (Approximately 100Tonnes at the CT interface). Each clamp arm pivots to provide access for installing pig launchers/receivers (if required) and increasing clearance to enable ancillary equipment (if required) to be installed upstream. At the CT/clamp interface there is an interchangeable clamp jaw to enable the clamp to hold a range of CT diameters (1”-5” typically). The inserts will be machined with a surface finish to suit the coating on the pipe. Typically a ‘button’ or ‘tooth’ profile will be used that will ‘bite’ into the surface of the coating creating high levels of friction and a reliable hold on the product. The assembly also has a pair of arms which hold coated rollers and proximity sensors to provide and record a working window for the coiled tube.

Main support Frame

The main frame assembly has interfaces to mount the coiled tubing installation equipment and provide accessibility to inspect the product and conduct welding and/or coating activities etc. The assembly weighs approximately 24Tonnes with an overall footprint of 2.1 x 11.5m. Access platforms attach directly to the main frame. All access platforms and the strut mount fabrication are flanged and bolted to the main frame to aid transportation. The screw jacks from the fleeting carriage assembly mount directly onto the main frame, providing the force required to alter the lay angle.

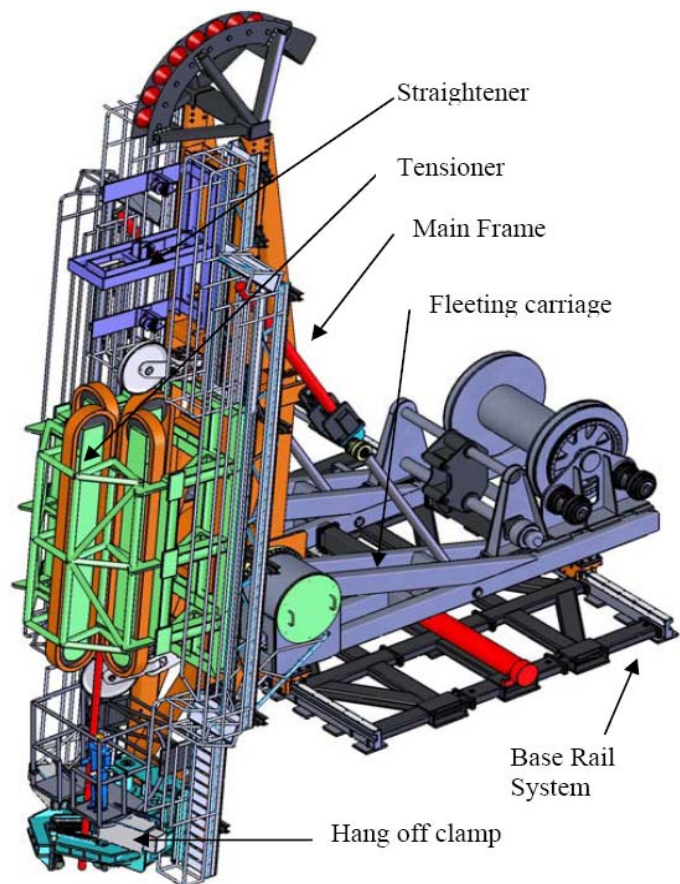

Figure 3 - Unit components

Fleeting Carriage Assembly

Each assembly houses a slewing ring that pivots for the lay angle adjustment. A pair of screw jacks driven by a hydraulic motor are used to raise and lower the unit to different angles, as shown in Figure 4. This provides the versatility to lay coiled tubing in a range of lay angles according to water depth of each development.

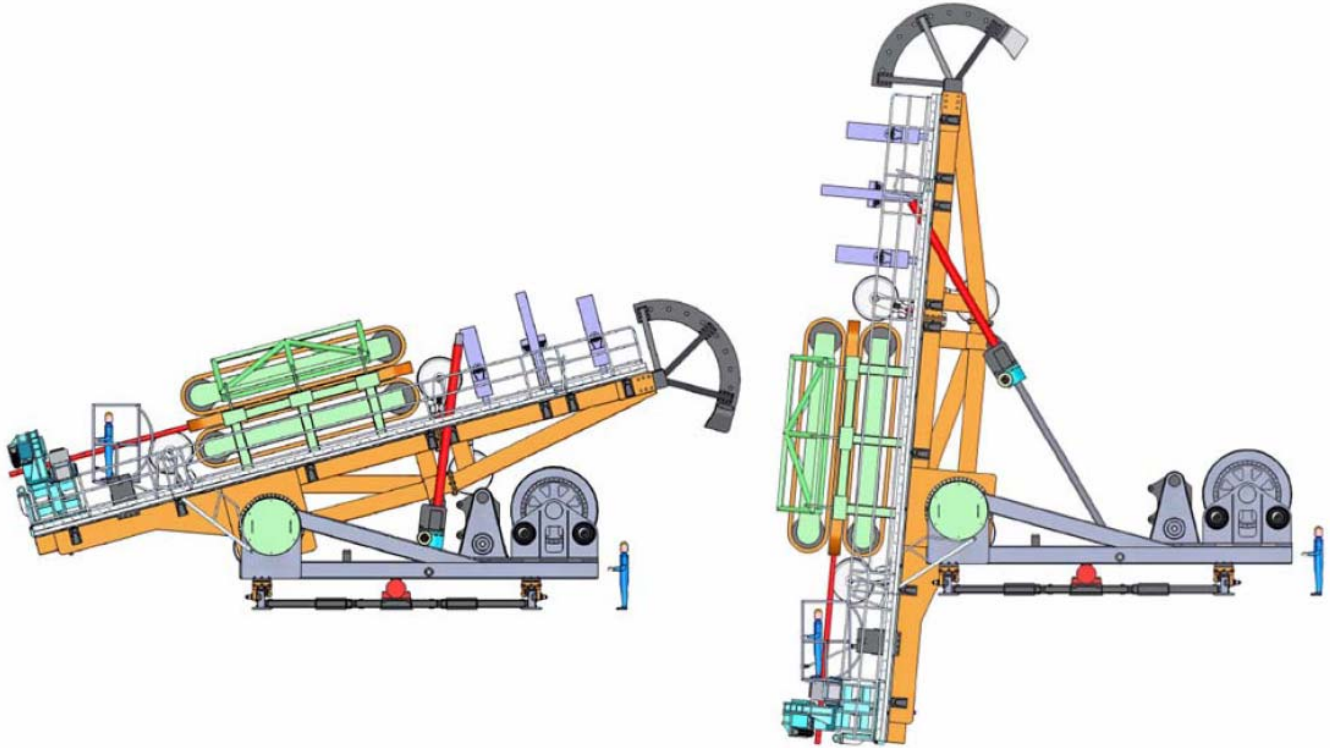

Figure 4 - Changing Installation Angle for Water Depth

Base Rail System

The base rail assembly provides the interface between the vessel deck and carriage assembly, with a foot print of 11.2m x 5.2m. The base rail is split into three sections flanged together, enabling the assembly to fit into a standard 40ft container.

The carriage is designed to fleet in synchronisation with the powered reel, a hydraulic cylinder providing the required force. The fleeting minimises strain on the coiled tube and out of plane loading on the roller arch. The carriage bearings react the dynamic loading of the rig during operation. The carriage provides a mounting platform for the slewing ring assemblies and the A&R winch mounting frame.

Deployment Analysis

In order to be an attractive alternative to flexible pipe, the coiled tubing must also be able to be installed in harsh offshore environments without overstressing the coiled tubing. Each diameter of coiled tubing must be capable of withstanding a number of concurrent loadings during deployment:

- Bending loads as a result of wave induced vessel movement
- High levels of tension from the length of tubing hanging between the back of the vessel and the seabed – in suspension
- Current loading along the length of the hanging pipe
- Compression at the touch down point (TDP) must be avoided at all times

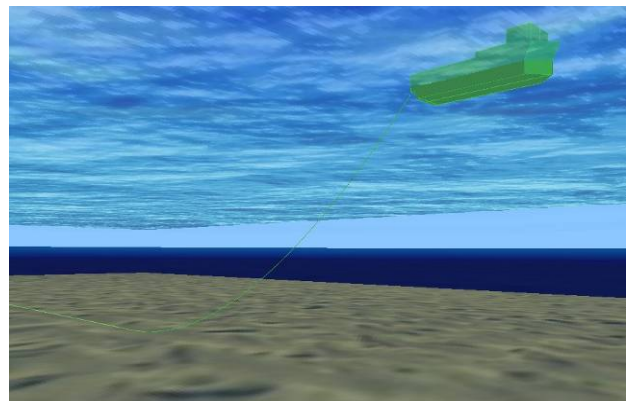

Figure 5 – Finite element model of CT deployment

- Hang off during termination or storm conditions

Each of these loadings has been analysed in detail, using finite element analysis software, assuming standard anchor handling vessel movements, as specified by Noble Denton, in water depths from 0m to 1400m, currents up to 0.75m/s and up to 6m significant wave height.

Analysis of these conditions shows that flexible pipe can be installed in a wide range of current and wave loading combinations, for a range of environmental conditions. Deployment windows are limited by compression at the TDP and by stresses at the roller box. Compression at the TDP can be alleviated by adjusting the lay angle of the unit from 10 to 30 degrees from the horizontal in shallow to medium water, and in the range of 50 to 84 degrees from the horizontal in deep water. Limiting wave heights are shown to be dependent on the wave direction and the specific RAO – Response Amplitude Operator - of the installation vessel.

Deployment and Operational Considerations

For the successful deployment of coiled tubing, a number of operational issues must be tackled. Optimisation of the loading operation depends on the scarcest resource. Ordinarily this would be the vessel but in some regions the availability of suitable cranes and capacity could affect the operation. Careful preparation of dockside and storage facilities must be undertaken for a successful deployment. A typical “shopping list” of required facilities, personnel and operational considerations is as follows:

Storage yard: Large quantities of coiled tubing of various diameters will need to be stored, preferably as close to the Port of Operations from which the coiled tubing will be loaded onto the vessel. A practical means of transportation between the storage yard and the quayside must also be available.

Vessel: Details of the vessel from which the coiled tubing is to be deployed are required relatively early in the project. The vessel draft, available deck space, number of available beds for operating staff, vessel RAOs and bollard pull capacity all affect the operability of installing coiled tubing. However, the requirements of the installation system described are not onerous, and even relatively small anchor handling vessels should be able to meet the necessary requirements.

Port of Operations: A key requirement for the deployment of coiled tubing is the selection of a suitable port of operations from which the coiled tubing will be spooled onto the installation vessel. The Port of Operations must provide the installation contractor with the following:

- A quayside of sufficient water depth to allow installation vessels of varying drafts to moor alongside for the installation of the coiled tubing and lay equipment.
- Access to a crane of suitable lifting capacity to lift the installation equipment onto the vessel. The crane must have sufficient reach and lifting capacity.
- An area next to the quayside in which to build the lay ramp main body and main deck reel. There must also be suitable location in which to set-up the dockside transpooling winch from which coiled tubing can be spooled onto the vessel from the dockside. It is, of course, possible to build the lay ramp on the vessel, but this costs ship time, which is generally an expensive resource.

Associated Equipment and Personnel: During the installation of coiled pipe, auxiliary components such as pig launchers, hydrotest equipment, vessel positioning software etc. must be available. Additionally, suitably experienced operators must be available on the vessel 24 hours and day, seven days a week. This may become an issue depending on how many free beds are available on the vessel. A recommended organigram for the offshore installations team is shown below in Figure 6. The team consists of a total of 16 engineers including a day and a night team as a standalone unit, but some members might be intergrated into the vessel crew if this is available.

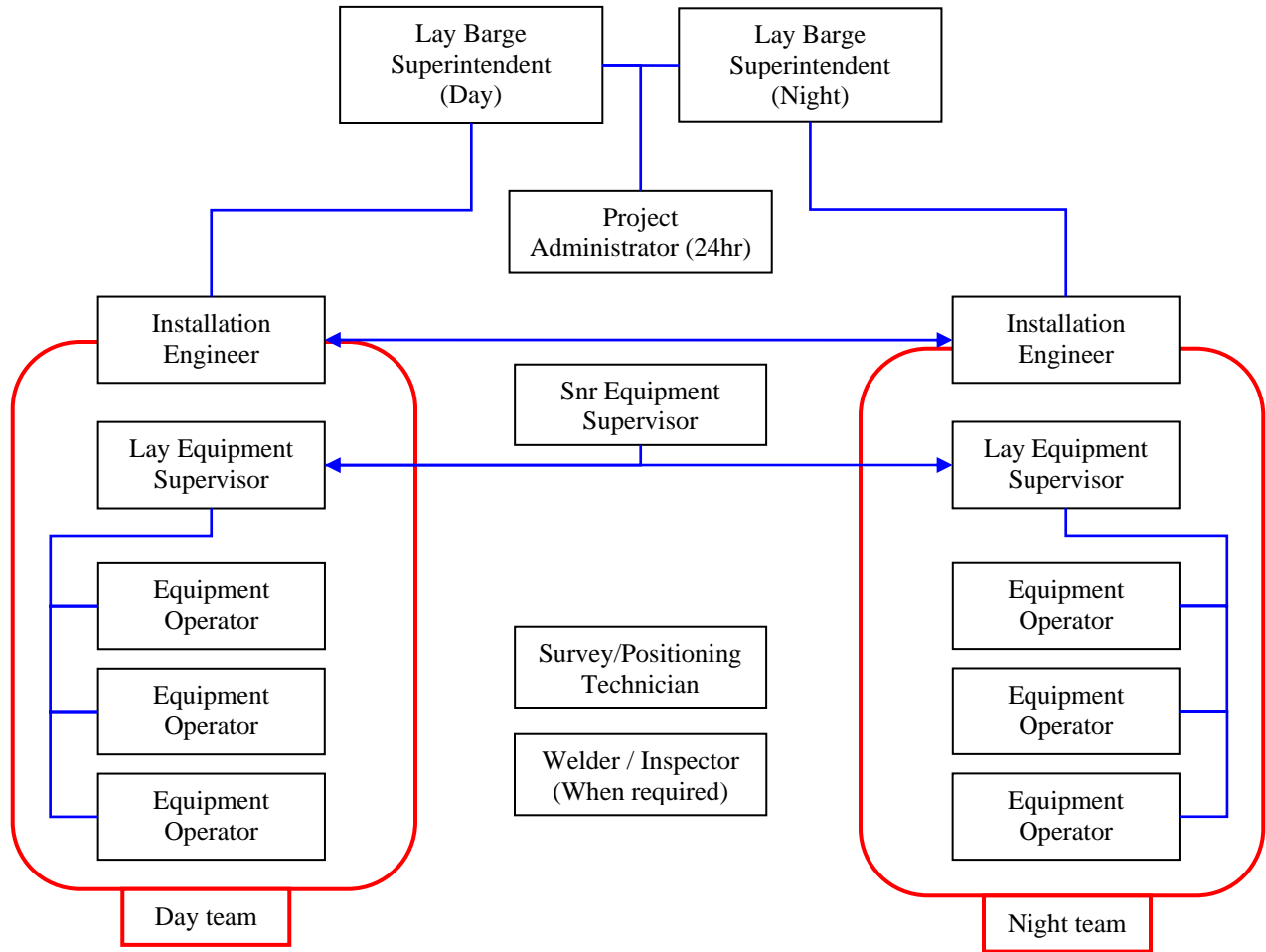

Figure 6 – Operations Team Organigram

Flexible Pipe Lay

Whilst the system described in this paper was originally aimed at coiled tubing lay operations, there is no reason why it cannot also be used to deploy flexible pipe, umbilicals or subsea cables using the same basic process. This makes the system versatile; able to do a number of different jobs from low cost vessels of opportunity.

System limitations

Whilst the described laying technique is ideally suited to laying coiled tubing in water depths from 40m to 1000m, in ultra-deepwater environments the significant suspended length of product which must be supported by a relatively small vessel becomes a considerable issue, requiring specific resolution. Additionally, the suspended length of tubing produces high levels of axial stress in the coiled tubing and this may limit project operating windows, depending upon the tubing performance parameters.

Conclusions

This paper shows that coiled tubing can be used as a viable alternative to flexible pipe in various offshore applications. The Aquatic coiled tubing Lay Ramp system is a modular, compact device which can be easily transported to any destination in containers, and assembled on the quayside. Once assembled the unit can be lifted onto the back of the vessel of opportunity, such as an anchor handling vessel, or PSV, and operated using a relatively small team in a wide range of environmental conditions.

Acknowledgments

The authors would like to thank contributions from Aquatic who have been the driving force behind this concept and commissioned 2H Offshore for the design work, as well as Richard Hockley of 2H who provided the technical drawings.