

2H Offshore - deep water riser engineering

2H  storm™

storm™

Subsea Tree Offset Riser Manifold

Field Development Solution with Riser and Well Systems Focus

By
Stephen Hatton
2H Offshore Engineering

2H Offshore - deep water riser engineering

2H  storm™

Dry Trees

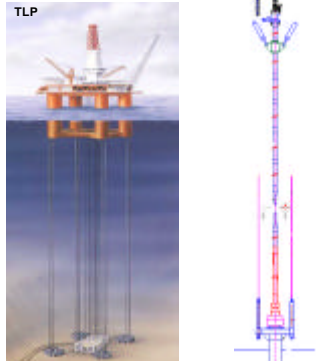

TLP

2H Offshore - deep water riser engineering

2H  storm™

TOP TENSION RISERS



HYDRO-PNEUMATIC TENSIONER SYSTEM AIRCAN SYSTEM

2H Offshore - deep water riser engineering

2H  storm™

Dry Trees

- Pros
 - Surface BOP & Trees
 - Ease of drilling and WO
- Cons
 - Vessel cost - Heave criticality
 - Riser weight, payload, cost
 - Vessel interface complexity
 - Expansion feasibility
 - Isolation well control
 - Clashing

Good Solution ?



2H Offshore - deep water riser engineering

2H  storm™ storm™

A Repackaged Riser Solution

1 - same drilling capability as DTU
2 - equivalent well access as DTU

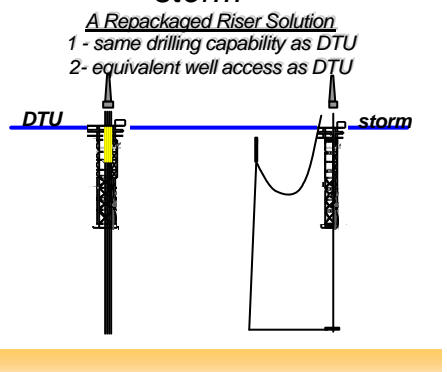

DTU storm

2H Offshore - deep water riser engineering

2H  storm™ storm™

storm™ spar

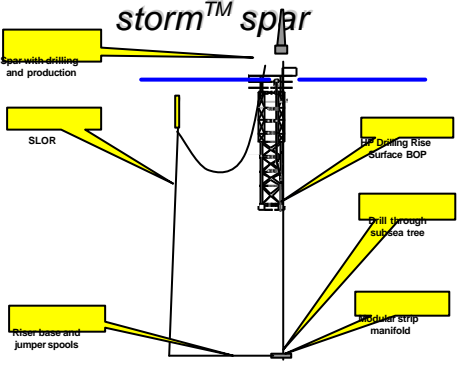

Spar with drilling and production

SLOR

Drilling Rise Surface BOP

Drill through subsea tree

Riser base and jumper spools

Driller strip manifold

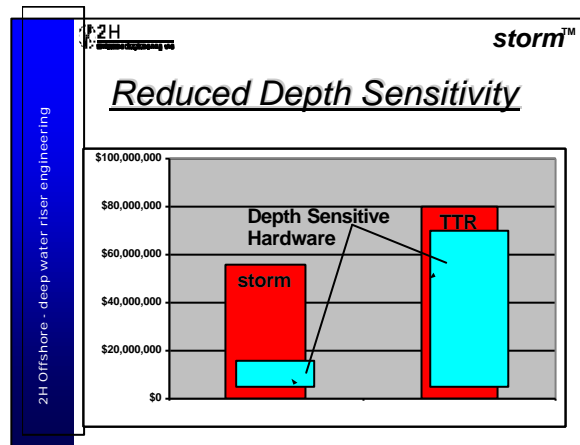
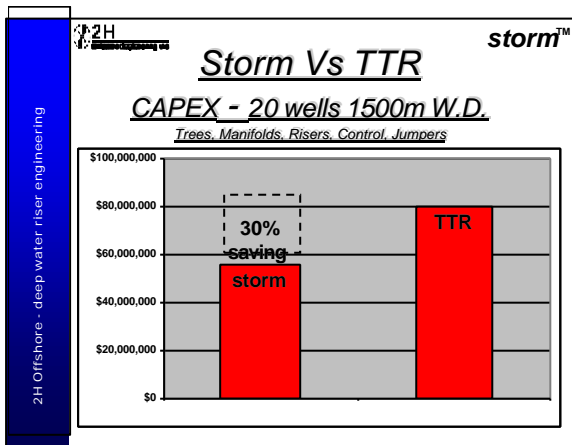
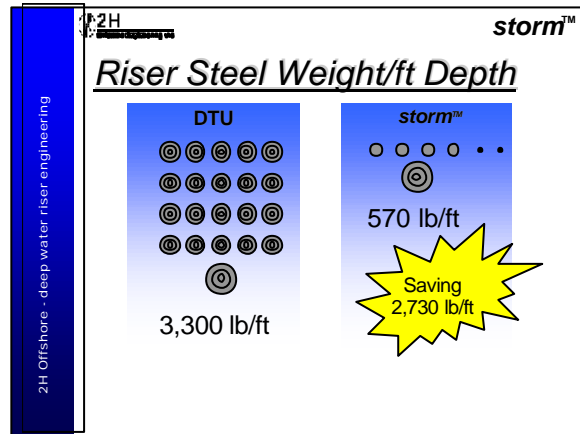
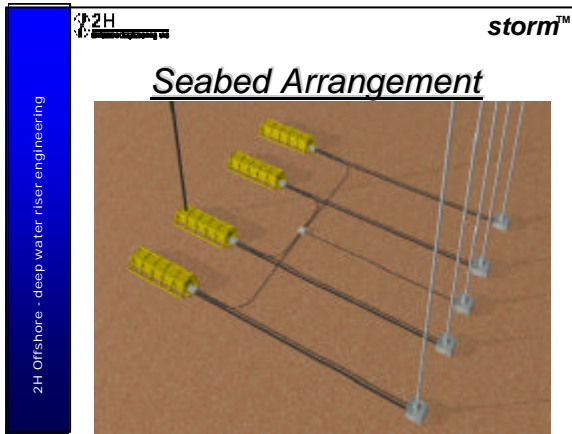

- Other Costs Issues**
- ❑ Reduced hull cost
 - ❑ Reduced deck cost
 - ❑ Reduced derrick and substructure cost
 - ❑ Eliminates heavy lift aircan installation
- 2H Offshore - deep water riser engineering
- storm™

- storm™ Spar**
- ❑ Improved safety
 - ❑ Eliminates HP risers
 - ❑ Subsea isolation
 - ❑ Eliminates production wellbay
 - ❑ Separates drilling & production
 - ❑ Eliminates clashing risk
 - ❑ Reduced cost
 - ❑ Reduced hull dia. & length
 - ❑ Low cost risers and subsea equip.
 - ❑ Min. offshore construction
 - ❑ No hull aircons
 - ❑ Flexibility (Expansion / Schedule)
 - ❑ Simplified interfaces
 - ❑ Well count flexibility - expansion 5-25
 - ❑ Predrill option - fast track production
 - ❑ Pre-installation of risers
-
- 2H Offshore - deep water riser engineering
- storm™

2H Offshore - deep water riser engineering

storm™ Semi

- Advantages as for Spar **PLUS**
- Reduced hull cost (DPL/Hull Steel = 2)
- Improved hull availability
- Conversion possibility
- Improved deck load capacity
- Improved deck space/layout
- Shorter development schedule
- No offshore deck mating
- Installation from semi
- Early production feasibility

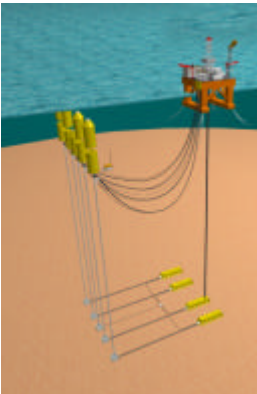

2H Offshore - deep water riser engineering

storm™

Modular 'Strip' Manifold

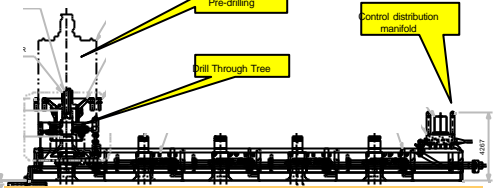

2H Offshore - deep water riser engineering

storm™

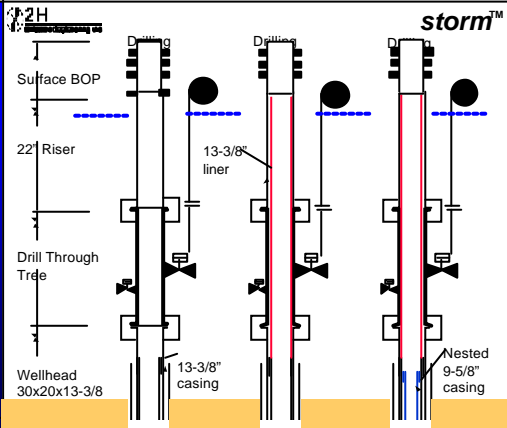

2H Offshore - deep water riser engineering

storm™

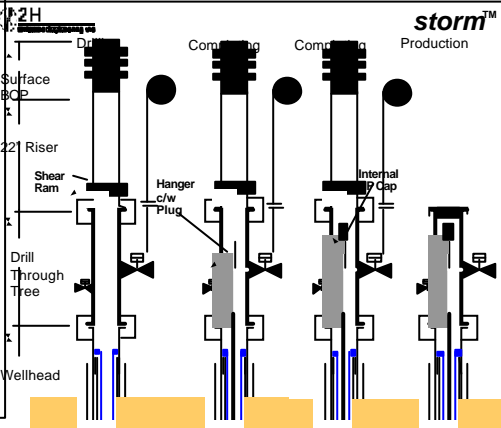

2H Offshore - deep water riser engineering

storm™

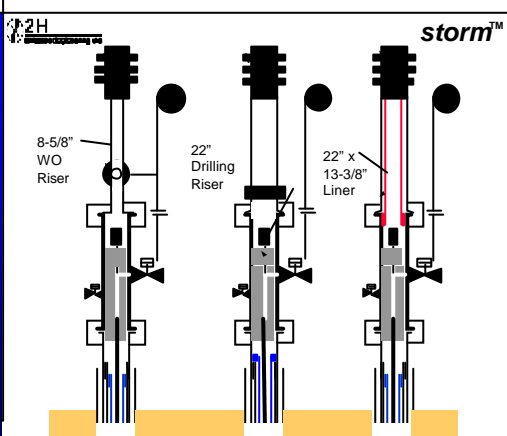

2H Offshore - deep water riser engineering

storm™

Drill Through Tree

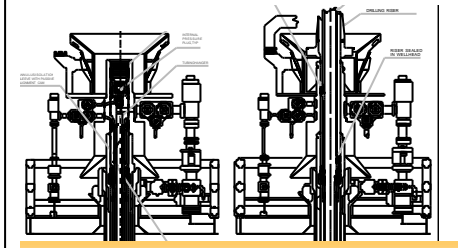

DTT Completed DTT with HP Drilling Riser

2H Offshore - deep water riser engineering

COR™/SLOR™
TRF JIP

Exxon/Mobil
bp
Total/Fina/Elf
Chevron
Texaco
British Gas
Conoco

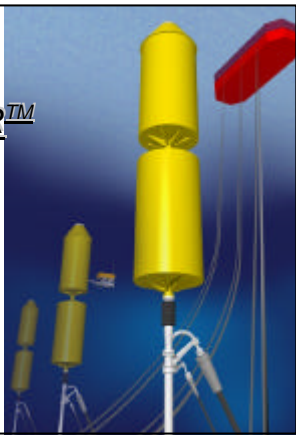

2H Offshore - deep water riser engineering

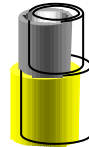

SLOR™
Single Line Offset Riser
Application - GI, WI (Production)

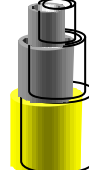

COR™
Concentric Offset Riser
Application – Production
Riser Base Gas Injection
Active Heating
N₂ or Vacuum Insulation

2H Offshore - deep water riser engineering

Modified Casing Connection

- ▣ High Grades P110
- ▣ Proven Metal Seal
- ▣ Fast Make-up
- ▣ SCF 2.5 - 4.5
- ▣ Environmental seal

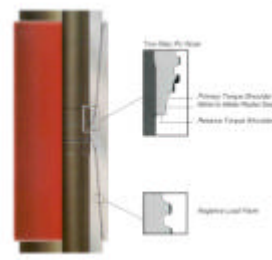

2H Offshore - deep water riser engineering

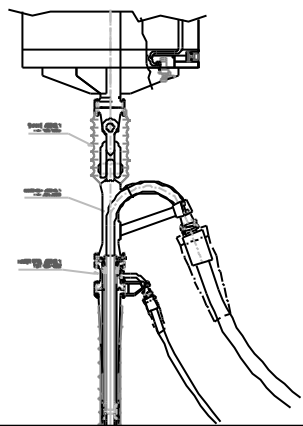

storm™

2H Offshore - deep water riser engineering

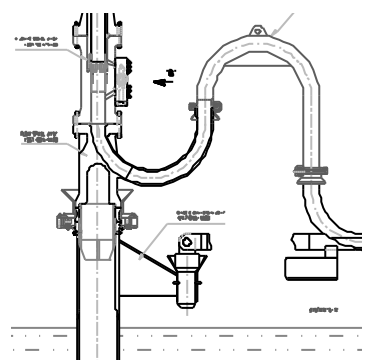

storm™

2H Offshore - deep water riser engineering

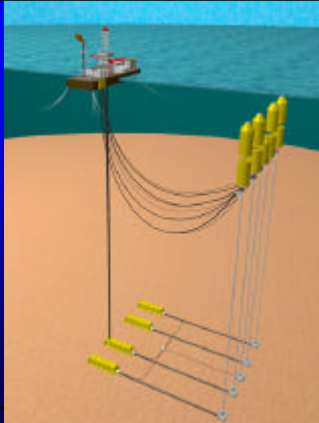

storm™
Storm Barge
West Africa

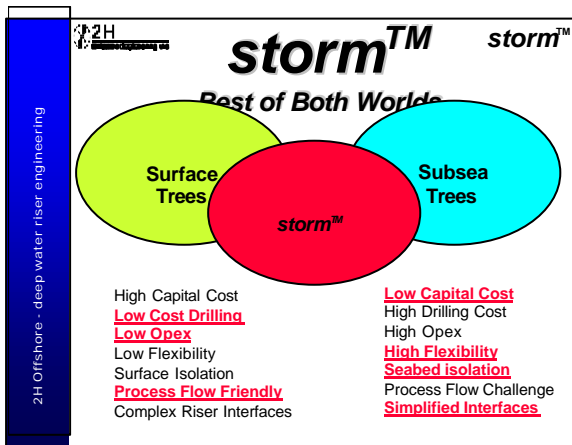
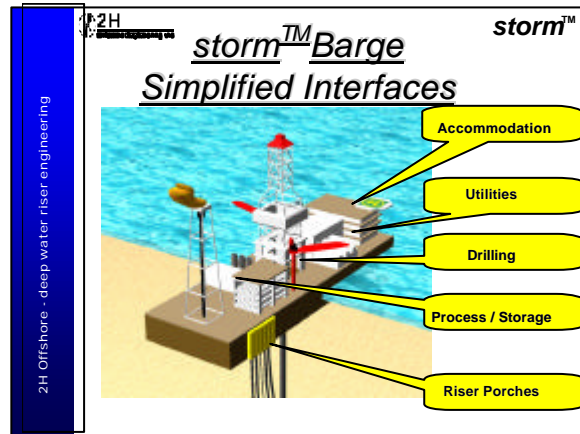
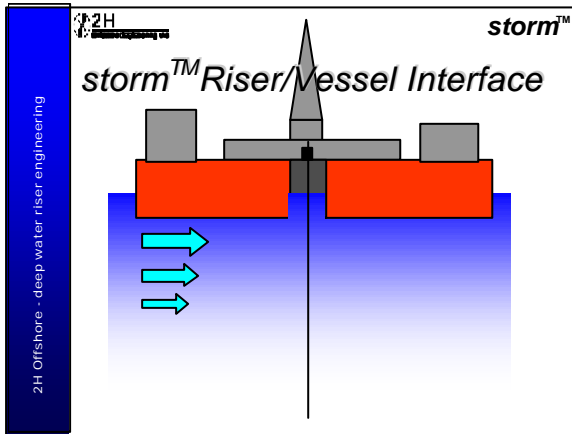

- storm™ Summary
- Riser & well system focus solution
 - Re-packaged proven hardware
 - Simplified interfaces
 - Safe Solution
 - Addresses key development costs
 - Drilling and well construction
 - Offshore construction (flowlines / risers)
 - Well intervention and WO
 - High flexibility (Wellcount, vessel type, EPS)
 - Cost effective (CAPEX and OPEX)
 - Deep and ultra deep water solution
 - GoM, Brazil, West Africa application
- 2H Offshore - deep water riser engineering